

Inches

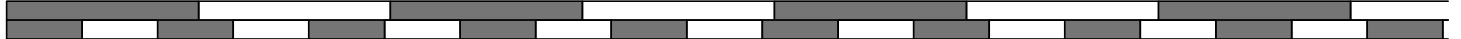

Centimetres

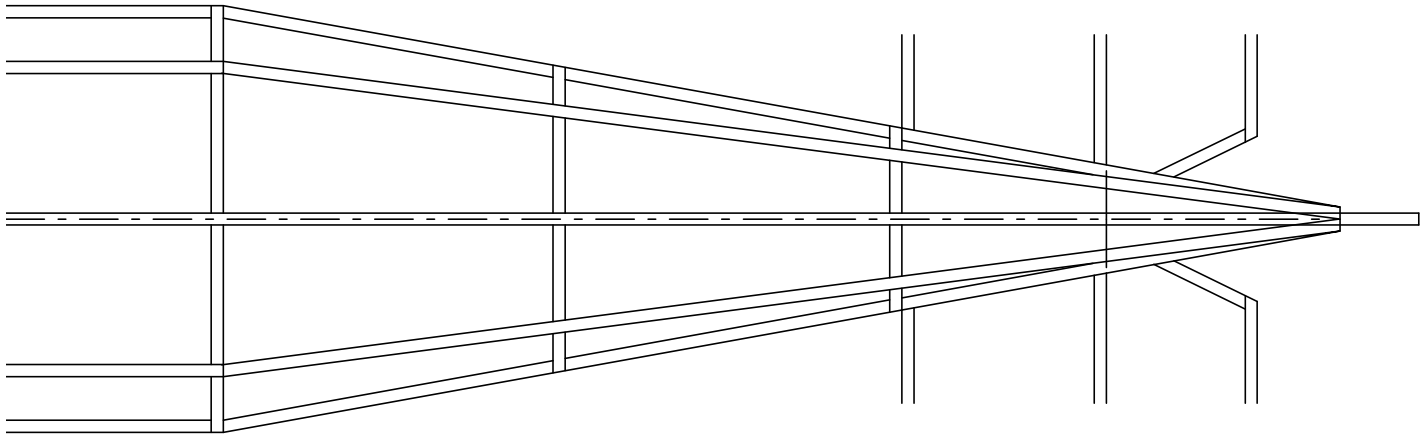

Installation details for geared KP-00 electric motor

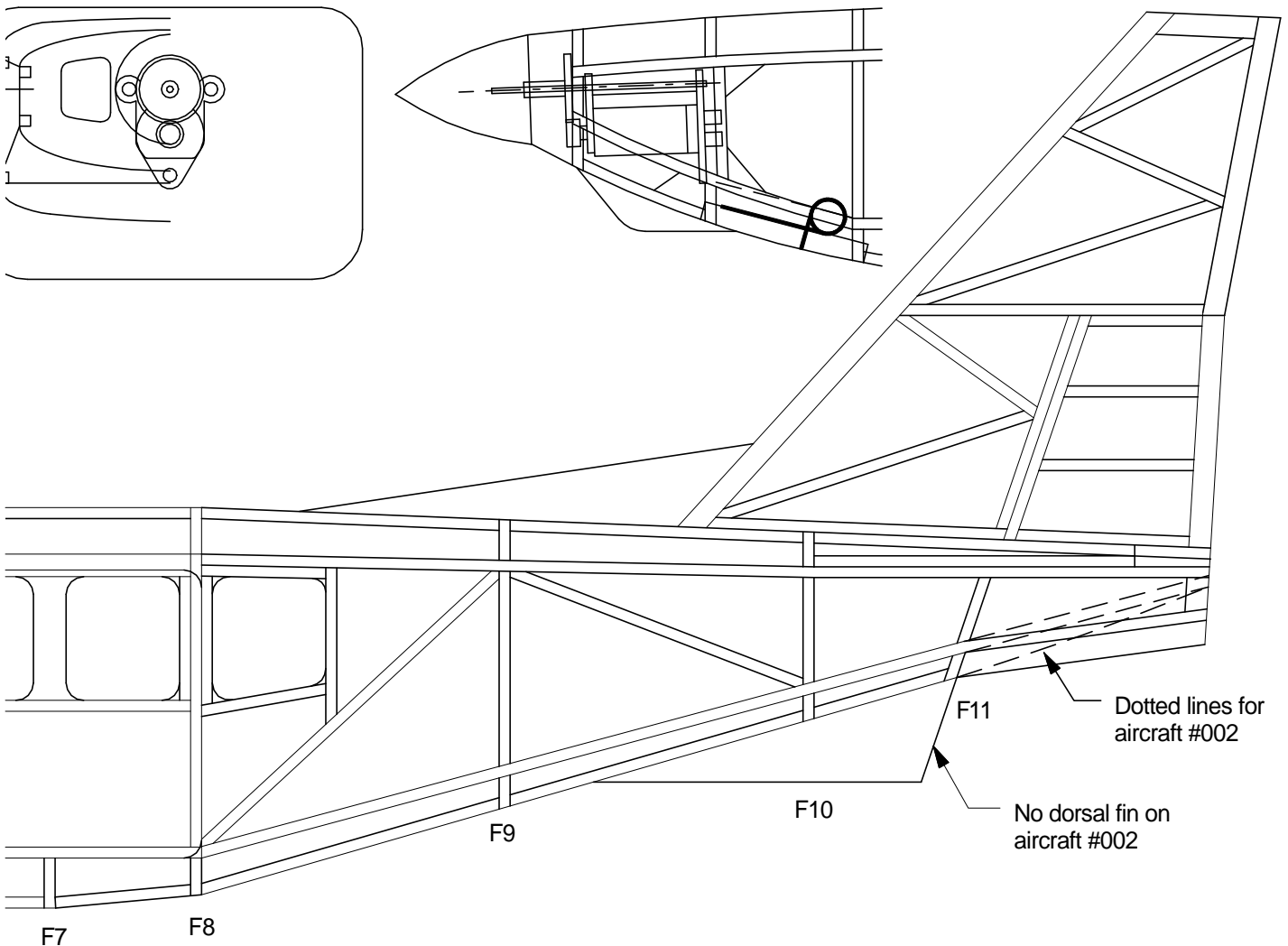
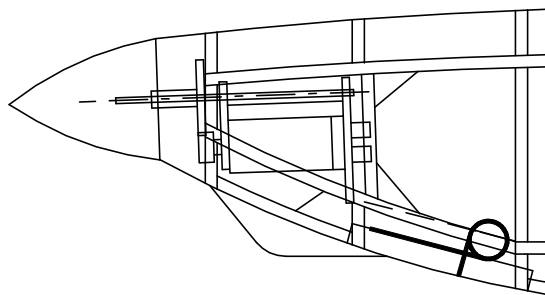
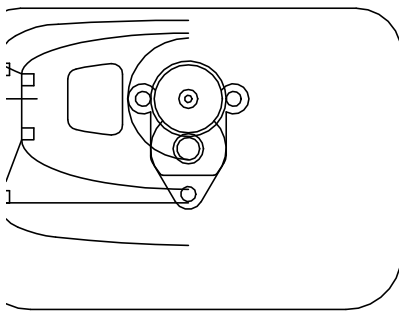

Gippsland Aeronautics GA-8 Airvan

Dimensions:	Prototype:	Model:
Span:	12.29 m	560mm (22.0")
Length:	6.70 m	369mm (14.5")
Wing area:	19.3 m ²	
Scale:		1:22
Model designed by Derek Buckmaster June 1999		



© D Buckmaster 1999
derekb@unite.com.au



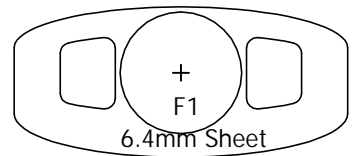
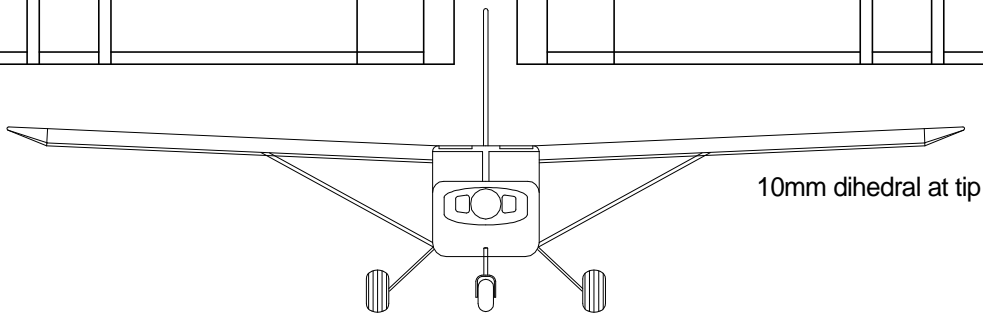
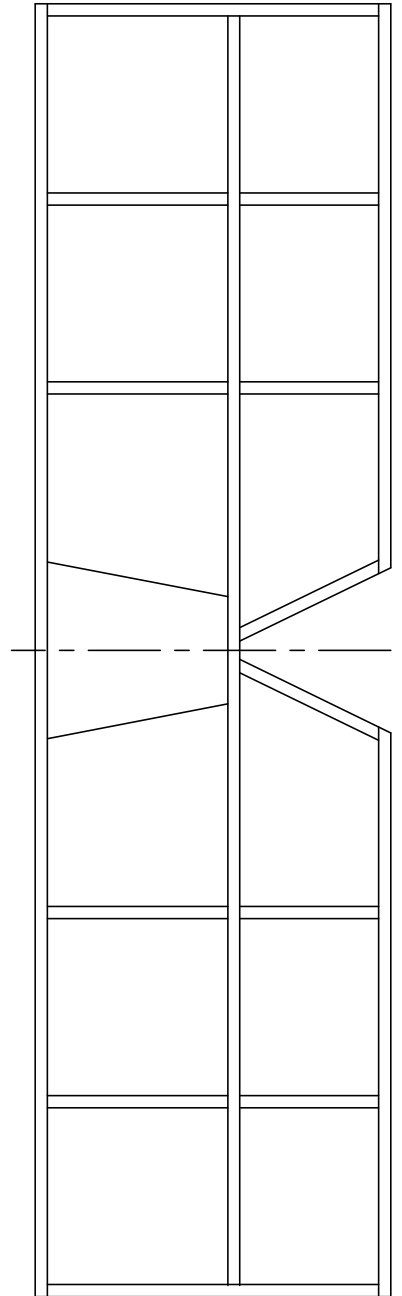
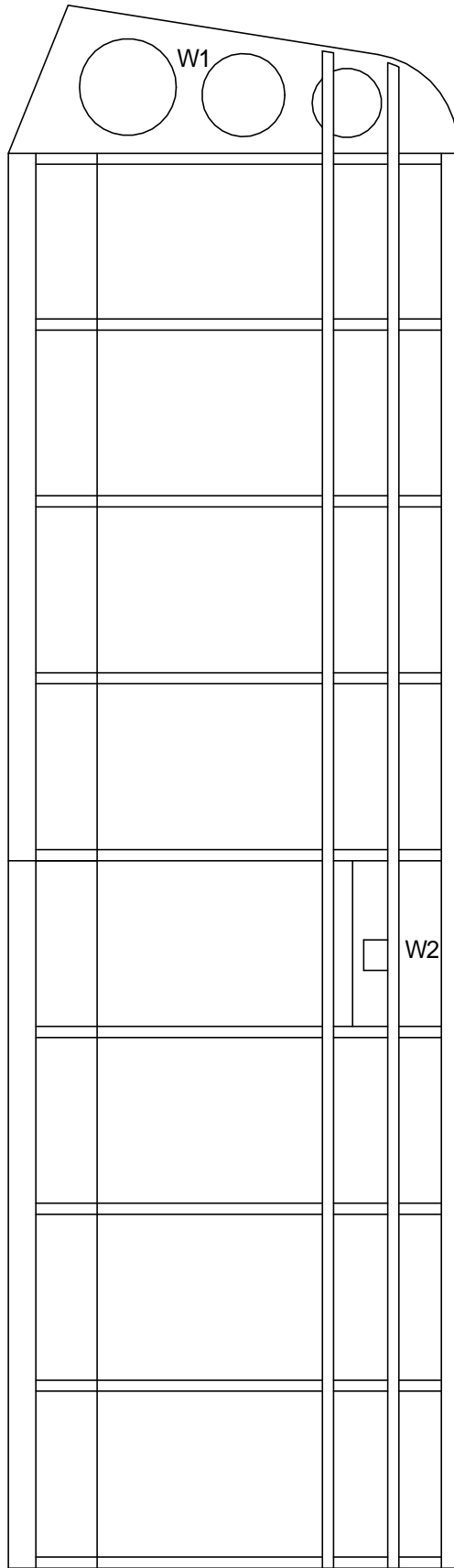
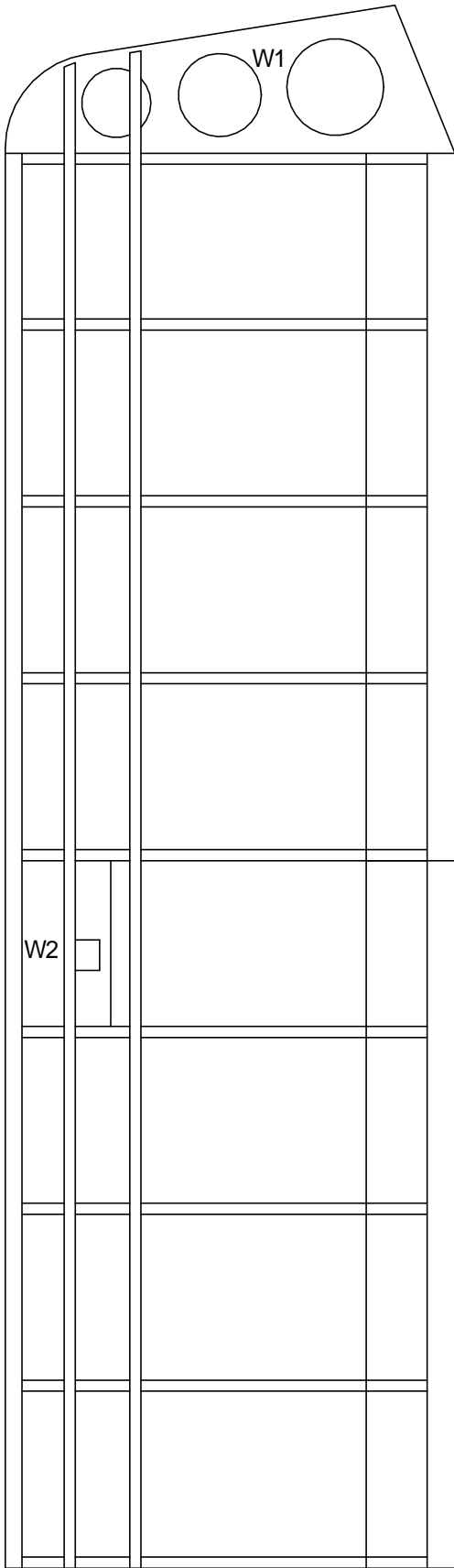

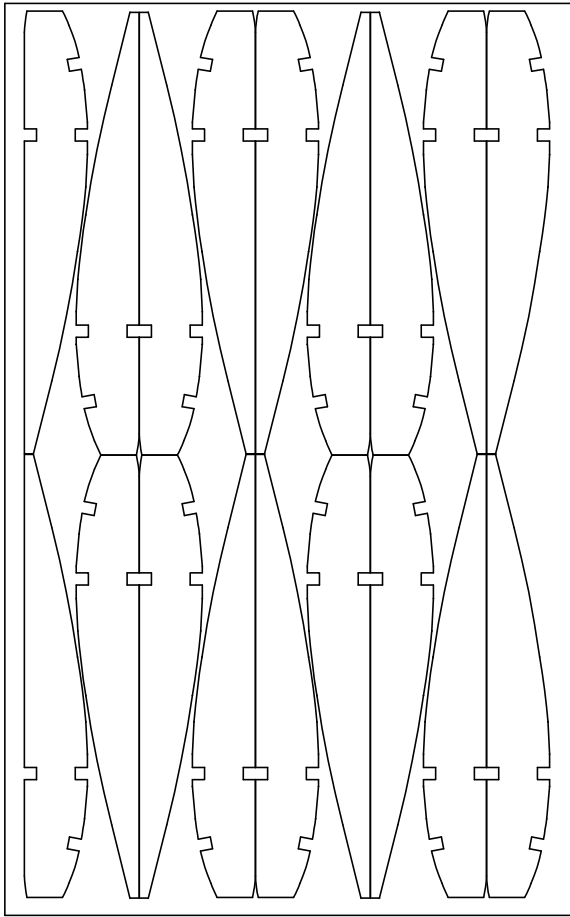

Nose landing gear wire pattern

